

A

B

C

D

E

F

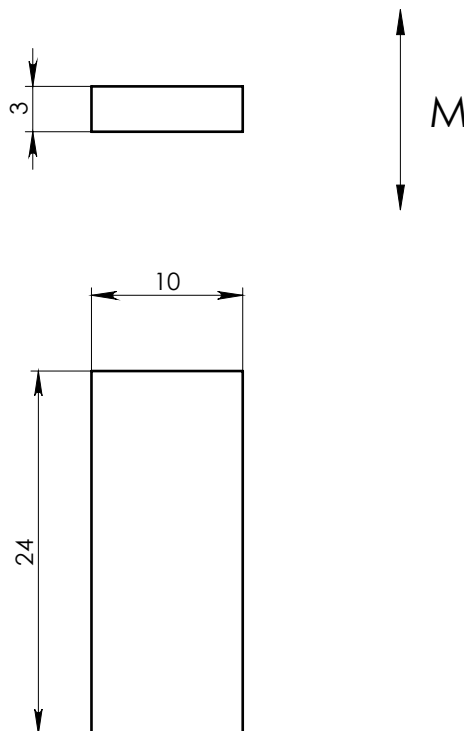



NOTE:
 1. Material: Grade - N35.
 2. Finish: Zn coated.

PART MUST COMPLIANCE WITH THE
 ROHS DIRECTIVE (2011/65/EU).

MAGNETIC CHARACTERISTICS:			
		CGS	SI
Br	MIN	11.7 kG	1.17 T
	MAX	12.2 kG	1.22 T
bHc	MIN	11.0 kOe	876 kA/m
jHc	MIN	12.0 kOe	955 kA/m
BHmax	MIN	33.0 MGOe	263 kJ/m ³
	MAX	36.1 MGOe	287 kJ/m ³

Working Temperature 80° max.

ASSEMBLY		NAME			SHEET 1		OF 1	
DWG.NO					NAME	DATE	SIGNATURE	
NDBR024010AMD		MAGNET NDBR024010A			Igor	13/10/2021		
	General Shape-and Position tolerance according DIN ISO 2768-mK		MATERIAL	NdFeB	DESIGNED	Igor	13/10/2021	
	Surface Finish: $\sqrt{3.2}$		MASS	5.40(gr)	DRAWN	Igor	13/10/2021	
	Control characteristics: - Important  - Critical 		SCALE	2:1	APPROVED	Rashid	13/10/2021	